



PROTECTION FILTER REACTORS

INA/INR Series

SERVICE AND COMMISSIONING INSTRUCTIONS

SERVICE AND COMMISSIONING INSTRUCTIONS FOR INA / INR FILTER REACTORS

DESCRIPTION OF THE EQUIPMENT

INA and **INR** reactors are designed to be used together with **FMF** capacitors to form harmonic protection filters.

As capacitors connected in series with reactors work at voltages higher than the network voltage it is no possible to use standard capacitors to build the filters. Use of **FMF** capacitors with both types of reactors is mandatory to avoid problems. The rating plate of the reactors shows the reference of the **FMF** capacitor to be used .

Reactors are thermally protected by means of a thermostat that disconnects the filter from the supply in case of overload.

INSTALLATION

Filters shall be protected against possible short-circuits by fuses or circuit breakers. Fuses shall be sized for 1.6 to 2 times the filter rated current.

Switching equipment shall be of enough capacity to withstand permanent and switching in currents of the capacitors (we recommend that you check suitable contactor size and type with the contactor manufacturer).

If filters are to be installed as an automatically regulated bank, depending on the time delay of the power factor controller, fast discharge resistors should be included in the contactors to ensure proper discharge of capacitors (See wiring diagram).

Location

- ③ Reactors are for indoor installation and in well ventilated places, away from heat sources.

Preparation

- ③ Check that rated voltage and frequency of the reactors and capacitors are the same as that of the mains to which are going to be connected
- ③ Ensure that power in the area that it is going to be handled has been disconnected

Connection of power circuit (See wiring diagram)

- ③ Connect the three phases (L1, L2 and L3) to the input terminals of the reactor (U1, V1 and W1) using a cable of appropriate section for the total power of the filter. The rating plates of the capacitors and reactors give the total current of the filter. In case of INA reactors brush aluminum busbars and use bimetallic (or tinned) terminals
- ③ Connect the three output terminals of the reactor (U2, V2 and W2) to the capacitor terminals

Wiring of protection circuit (See wiring diagram)

- ③ Connect the thermal protector in series with the contactor coil (Thermostat is set to trip at 90°C)

COMMISSIONING

Once checked that installation of the bank is correct, proceed to its commissioning taking into account the following points:

Temperature

The operating temperature is an extremely important parameter for reliable operation of reactor and capacitor. Maximum ambient temperature for **INA / INR** reactors is +45°C (This limit should be revised if reactors are in operation at an altitude above 1000 m sea level). If ambient temperature is higher, refrigeration has to be improved by increasing natural convection or by setting a forced convection.

Voltage

Reliable operation of the equipment requires that the service voltage does not exceed the rated voltage. It should be kept in mind that operations under overload conditions shortens considerably life of power capacitors.

Current

It should be checked that the rms value of the current drawn by the filter should not exceed 1.15 times the rated current indicated in the rating plate.

In order to avoid errors in the measurements, only “true rms” meters should be used to measure the filter current.

MAINTENANCE

Maintenance works will be made bearing in mind what indicated in chapter 5 Safety. Reactors and power capacitors require only a vary limited maintenance, yet is very convenient for reliable operation. The following operations are recommended:

Monthly

- Check reactors visually
- Examine protection fuses
- Check temperature and the thermal protection of the reactors

Annually

- Keep clean reactor terminals and capacitor terminals and insulators
- Check that terminal connections are tight
- Check the state of the contactor contacts
- Inspect fast discharge resistors
- Check the current (use a “true rms” ammeter)

SAFETY

ATTENTION: Before performing any maintenance operation or handling any part of the filter, remove all the power and control fuses and check that capacitors are discharged.

Even when the filter is disconnected from the mains, capacitors may still be charged. Therefore, after removing the fuses, wait for three minutes and then short circuit and earth the terminals or outlet cables of each capacitor

GUARANTEE

INTERNATIONAL CAPACITORS guarantees its products against any manufacturing defect for a period of TWO YEARS from the date of sale. In no case shall this guarantee will last longer than three years from the date of manufacture.

In the case of banks with automatic regulation, this guarantee does not cover neither protective devices (fuses) nor the spare parts of the which are subject to wear and tear.

INTERNATIONAL CAPACITORS will repair or replace, as it deems fit, any defective product that is returned during the guarantee period.

This guarantee remains null and void if installation and maintenance instructions of the product have not been followed or if the product has been some way misused.

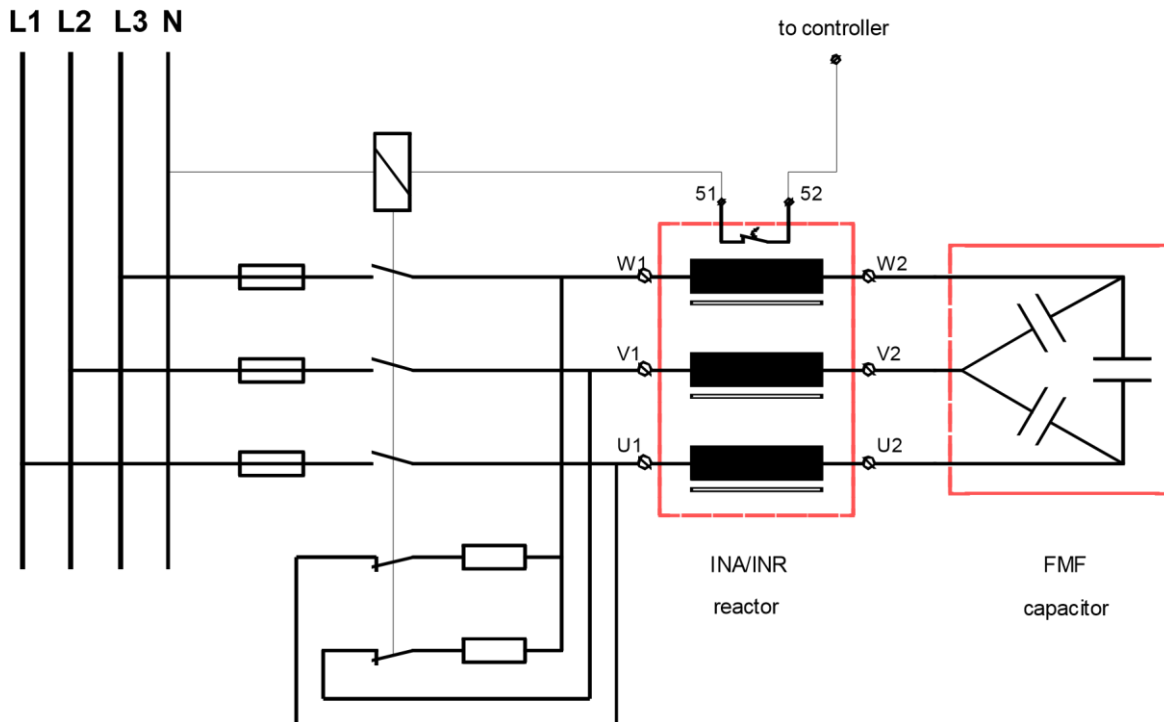

TECHNICAL SERVICE

In case of any equipment failure or any operational queries, please contact the technical service of INTERNATIONAL CAPACITORS, S.A.

INTERNATIONAL CAPACITORS S.A. – *After sales service*
 Polígono industrial de Palau, s/nº
 08400 GRANOLLERS (Barcelona)
 Tel. (34) 93 861 14 60 Fax
 (34) 93 879 26 64

E-mail : info@lifasa.com www.lifasa.com